



AirWS-100

Ultrasonic fill-level sensor



Characteristics

- The sensor informs about the fill volume condition of the container, the waste container, may trigger a requirement to empty it. It also informs you of the actual temperature in the scanning area.
- It has a built-in sensor for opening the lid or for tipping over the waste container.
- With wireless technology and its compactness, the device can be used in a variety of applications.
- Reliable measurement, regardless of material colour, transparency, gloss and interference light.
- With the wireless solution and Sigfox / LoRa / NB-IoT communication, it can communicate instantly to your chosen location and be operated immediately.
- Data is sent to the server from which it can be subsequently displayed as a smartphone, application, or Cloud notification.
- Battery status information is sent as a message to the server.
- Power: 2x Li-SOCL₂, 3.6V (integrated) battery life up to 8 years according to frequency of measurement and message transmission.
- The IP65 is suitable for installation in demanding environments.

Description

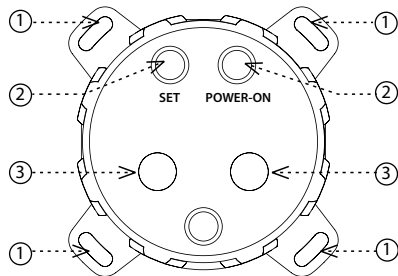

1. Mounting hole Ø 5 mm
2. Magnetic contact
3. Ultrasonic sensor
4. Seal

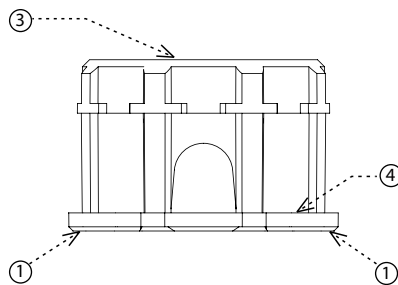

Cloud app assignment

It is done in your Smartphone application. Enter the relevant information on the product cover into the application.

General instructions

Internet of Things (IoT)

- The IOT wireless communications category describes the Low Power Wide Area (LPWA). This technology is designed to provide full-range coverage both inside and outside buildings, energy-saving and low-cost operation of individual devices. Individual networks - Sigfox, LoRa, NarrowBand - are available to use this standard.

Sigfox network information

- The network supports bidirectional communication but with a limited number of feed-backs. It uses the free frequency band divided by Radio Frequency Zones (RCZ).
 - RCZ1 (868 MHz) Europe, Oman, South Africa
 - RCZ2 (902 MHz) North America
 - RCZ3 (923 MHz) Japan
 - RCZ4 (920 MHz) South America, Australia, New Zealand, Singapore, Taiwan
- Sigfox has more coverage across countries, so it is better suited for long distance monitoring.
- For more information on this technology, please visit www.sigfox.com.

LoRa network information

- The network is bidirectional and its communication uses free frequency band.
 - 865 - 867 MHz India
 - 867 - 869 MHz Europe
 - 902 - 928 MHz North America, Japan, Korea
- The advantage of this network is the possibility of freely deploying individual stations in local locations, thus strengthening their signal. It can therefore be used efficiently in company premises or, for example, in local parts of cities.
- For more information on this technology, please visit www.lora-alliance.org.

Information about the NarrowBand network

- The network provides two-way communication and the only one to use the licensed LTE band. Our devices allow band 1 (2100MHz), Band 3 (1800MHz), Band 8 (900MHz), Band 5 (850MHz), Band 20 (800MHz) and Band 28 (700MHz).
- It uses this SIM card technology for each device.
- The advantage of NarrowBand is the use of already built-up grids, which ensures sufficient reception outside and inside buildings.
- For more information on this technology, please visit www.vodafone.cz

Caution for proper operation:

- Products are installed according to the wiring diagram given for each product.
- For proper device functionality, it is necessary to have sufficient coverage of the selected network at the installation site.
- At the same time, the device must be registered in the network. Successful device registration on a given network requires a charge for traffic.
- Each network offers different tariff options - it always depends on the number of messages you want to send from your device. Information on these tariffs can be found in the current version of the ELKO EP pricelist.

Function

The sensor measures the temperature in the space every minute, simultaneously detects the position of the sensor (e.g. opening the lid, tipping over the waste container, etc.). At twelve hours *, ultrasonic sensors scan the distance between the sensor and the surface being scanned.

Data reports measured values sent in twelve-hour period*. In the case of detecting changes in position of the sensor (opening of the lid, etc.) in 5 minutes*. In the event of a sharp rise in temperature it is reported immediately.

Settings: by using supplied magnet (included in the supply).

* Intervals can be set by message from the server.

Technical parameters

AirWS-100S AirWS-100L AirWS-100NB

Power supply		non-removable battery
Battery power:	2 x Li-SOCl ₂ , 3.6V	
Battery life:	up to 8 years according to frequency of measurement and message transmission	
Battery status view:	message to the server	

Setting	
Setting:	With a message from the server, magnetic keys, RFAF/USB Service Key
Measured values:	message to the server

Fill detection	
Detection principle:	ultrasonic
Range:	5 - 300 cm
Resolution:	1 cm*

Input	
Temperature measuring:	built-in sensor
Range:	-30 .. 85 °C
Sensitivity:	1 °C
Accuracy:	± 3 °C

Position detection	
Tilt sensing:	digital sensor
Angle:	± 180 °
Accuracy:	± 5 °

Communication			
Protocol:	iNELS RF Control RFIO**		
Transmitter frequency:	868 MHz		
Range in open space:	up to 20m		
Protocol:	Sigfox	LoRa	NB-IoT
Transmitter frequency:	RCZ1 868 MHz	868 MHz	LTE Cat NB1***
Range in open space:	Approx. 50 km****	Approx. 10 km****	Approx. 30 km****
Transmission power (max.):	25 mW / 14 dBm	25 mW / 14 dBm	200 mW / 23 dBm

Other parameters	
Working temperature:	-30...+85 °C
Storage temperature:	-30...+85 °C
Operation position:	sensing contacts downwards
Mounting:	screws
Protection degree:	IP65
Dimension:	Ø 97 x 62 mm

* Depending on type and content storage.

** For service purposes.

*** Multiple frequency bands of B1 / B3 / B5 / B8 / B20 / B28.

**** Depending on network coverage.

Warning

Read the operating instructions before installing the device and putting it into operation. Instruction manual is designated for mounting and also for user of the device. It is always a part of its packing. Installation and connection can be carried out only by a person with adequate professional qualification upon understanding this instruction manual and functions of the device, and while observing all valid regulations. Trouble-free function of the device also depends on transportation, storing and handling. In case you notice any sign of damage, deformation, malfunction or missing part, do not install this device and return it to its seller. It is necessary to treat this product and its parts as electronic waste after its lifetime is terminated. Before starting installation, make sure that all wires, connected parts or terminals are de-energized. While mounting and servicing observe safety regulations, norms, directives and professional, and export regulations for working with electrical devices. Do not touch parts of the device that are energized – life threat. To ensure the transmission of the radio signal, make sure that the devices in the building where the installation is installed are correctly located. Unless otherwise stated, the devices are not intended for installation in outdoor and damp areas, they must not be installed in metal switchboards or in plastic cabinets with metal doors - this prevents transmission of the radio frequency signal. iNELS Air is not recommended for controlling life-saving instruments or for controlling hazardous devices such as pumps, heaters without thermostat, lifts, hoists, etc. - radio frequency transmission may be overshadowed by obstruction, interference, transmitter battery may be discharged etc., thereby disabling the remote control.

Assembly

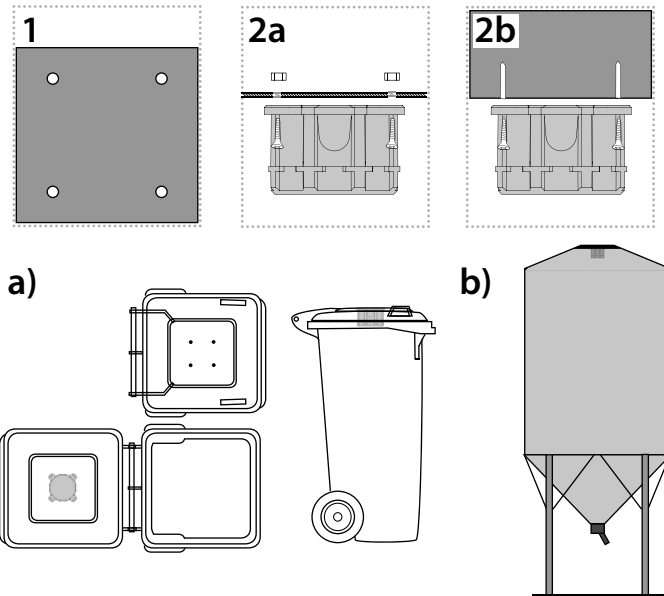

1. Drill four holes of the appropriate diameter into the substrate; corresponding to the position of the holes in the sensor (you can use the sensor as a drilling template).

2a. Installation on the garbage can lid (material thickness 1-5 mm): attach the sensor so that the ultrasonic sensors are directed into the container. Fasten with suitable fasteners according to substrate. For example, a blind rivet Ø 5 mm, min. 15mm length or M5x15 screw with nut.

2b. Surface Mount: insert the dowels into the holes, attach the detector with a suitable fastener so that the ultrasonic sensors are directed into the container. For example, a dowel screw, a screw Ø of 5 mm and a length of 40 mm can be used as a suitable fastener.

Recommendations for installation

- The sensor is suitable for outdoor use. Operating conditions are consistent with conventional chemically non-aggressive environments.
- Before mounting, check the range. Ensure the correct location - see Warning (must not be placed in metal containers, etc.).
- The recommended working orientation is vertical, ultrasonic sensors down to the scanned area.
- Do not cover the sensor as this may reduce signal transmission.
- The sensor's immediate surroundings must remain free for proper detection. The bottom of the sensor should not touch the contents even when it is full.
- Keep the ultrasonic sensors clean for proper operation.

Commissioning

To activate the detector, place the magnet on the POWER-ON magnetic contact for 5 seconds and then on the magnetic contact SET for 3 seconds. The detector sends a start message.

After activation, calibrate the detector by applying the magnet to the SET magnetic contact for 9 seconds and place the sensor in the working position (close the waste container lid). After successful calibration (40 seconds), the detector sends a message.

You can also perform calibration and detector setup in the application or using the RFAF/USB Service Key and to lock the detector against manual adjustment.